

# Output Constraints from FPGA Spec

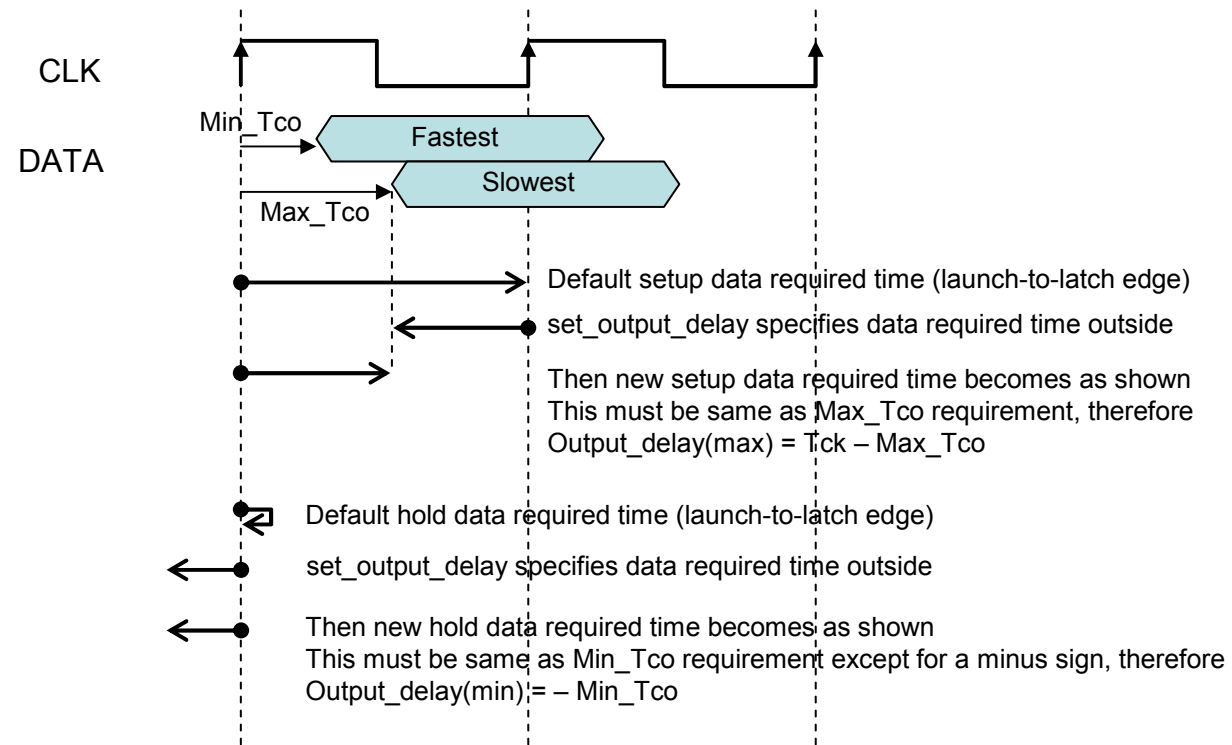

# Output Constraints from Other Device Spec

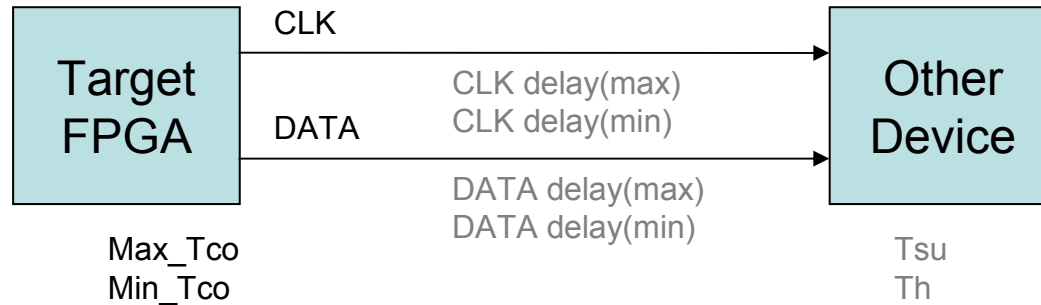